

# CB-27T, TBX-68T, AND CB-68T ISOTHERMAL TERMINAL BLOCKS

This installation guide describes how to install and connect signals to the CB-27T, TBX-68T, and CB-68T isothermal terminal blocks for use with the NI 435X, which includes the NI 4350 (ISA) for the ISA bus, the NI 4350 (PCMCIA) for computers with Type II PCMCIA slots, NI 4350 (USB) for computers that are USB compatible, NI 4351 (PXI) for PXI and CompactPCI chassis, and NI 4351 (PCI) for PCI bus computers.

## Introduction

---

The CB-27T isothermal terminal block is a shielded board with screw terminals that connects to the NI 4350 (PCMCIA) input/output (I/O) connector.

The TBX-68T isothermal terminal block is a DIN rail-mountable terminal block that consists of a shielded board with screw terminals and digital signal conditioning accessory connections. It connects to the NI 435X (ISA, USB, PXI, PCI) I/O connector.

The CB-68T isothermal terminal block is a CA-1000 enclosure-mountable terminal block that consists of a shielded board with screw terminals and digital signal conditioning accessory connections. It connects to the NI 435X (ISA, USB, PXI, PCI) I/O connector.

The terminal blocks can easily accommodate thermocouples, resistance temperature detectors (RTDs), thermistors, and voltage signals. The terminal blocks feature isothermal construction to minimize the temperature gradients across the screw terminals and a high-accuracy thermistor cold-junction temperature sensor for measuring with thermocouples. Enclosures keep out air currents to maintain an isothermal environment for the screw terminals and the cold-junction sensor. The TBX-68T mounts on most European standard DIN EN mounting rails. The TBX-68T and CB-68T also have connectors for cables from selected relay and digital signal conditioning modules.

The terminal blocks provide connections to all digital I/O lines on the NI 435X. The terminal blocks also provide connections to all but two analog input channels (CH)—CH0 is dedicated for the cold-junction sensor and CH1 is dedicated for auto-zeroing circuitry. Refer to the *NI 4350/4351 User Manual* for further details on these two channels.

## What You Need to Get Started

---

You need the following to set up and use your terminal block:

- One of the following NI 435X devices:
  - NI 4350 (PCMCIA, ISA, USB)
  - NI 4351 (PXI, PCI)
- NI 4350/4351 User Manual*
- CB-27T, TBX-68T, and CB-68T Isothermal Terminal Blocks Installation Guide*
- One of the following isothermal terminal blocks:
  - NI 4350 (PCMCIA)
    - CB-27T isothermal terminal block
  - NI 435X (ISA, USB, PXI, PCI)
    - TBX-68T isothermal terminal block
    - CB-68T isothermal terminal block
- One of the following cable assemblies:
  - NI 4350 (PCMCIA)
    - PSH32-30F shielded cable
  - NI 435X (ISA, USB, PXI, PCI)
    - SH6868 shielded cable (recommended)
    - R6868 ribbon cable
- Tie wraps (for CB-27T installation only)
- 1/8 in. flathead screwdriver
- No. 1 Phillips-head screwdriver
- Wire cutters
- Wire insulation strippers

For the CB-68T only:

- CA-1000 accessory enclosure
- CA-1000 Configurable Connector Accessory Enclosure Installation Guide*

For digital signal conditioning only:

- Digital signal conditioning accessory and its documentation
- NB7 or NB8 cable as required

## CB-68T Installation

---

Refer to Figure 1 as you perform the following steps to install the CB-68T into the CA-1000 enclosure:

1. Remove the top cover of the CA-1000 by unscrewing the eight screws with a Phillips-head screwdriver. Remove the cover.
2. Remove the rear panel of the CA-1000 enclosure by unscrewing the four screws at the top of the panel using a Phillips-head screwdriver.
3. Remove one of the half-panelettes (either the left or the right) by removing the screw at the top of the panelette. If installing two CB-68T units, remove both half-panelettes.



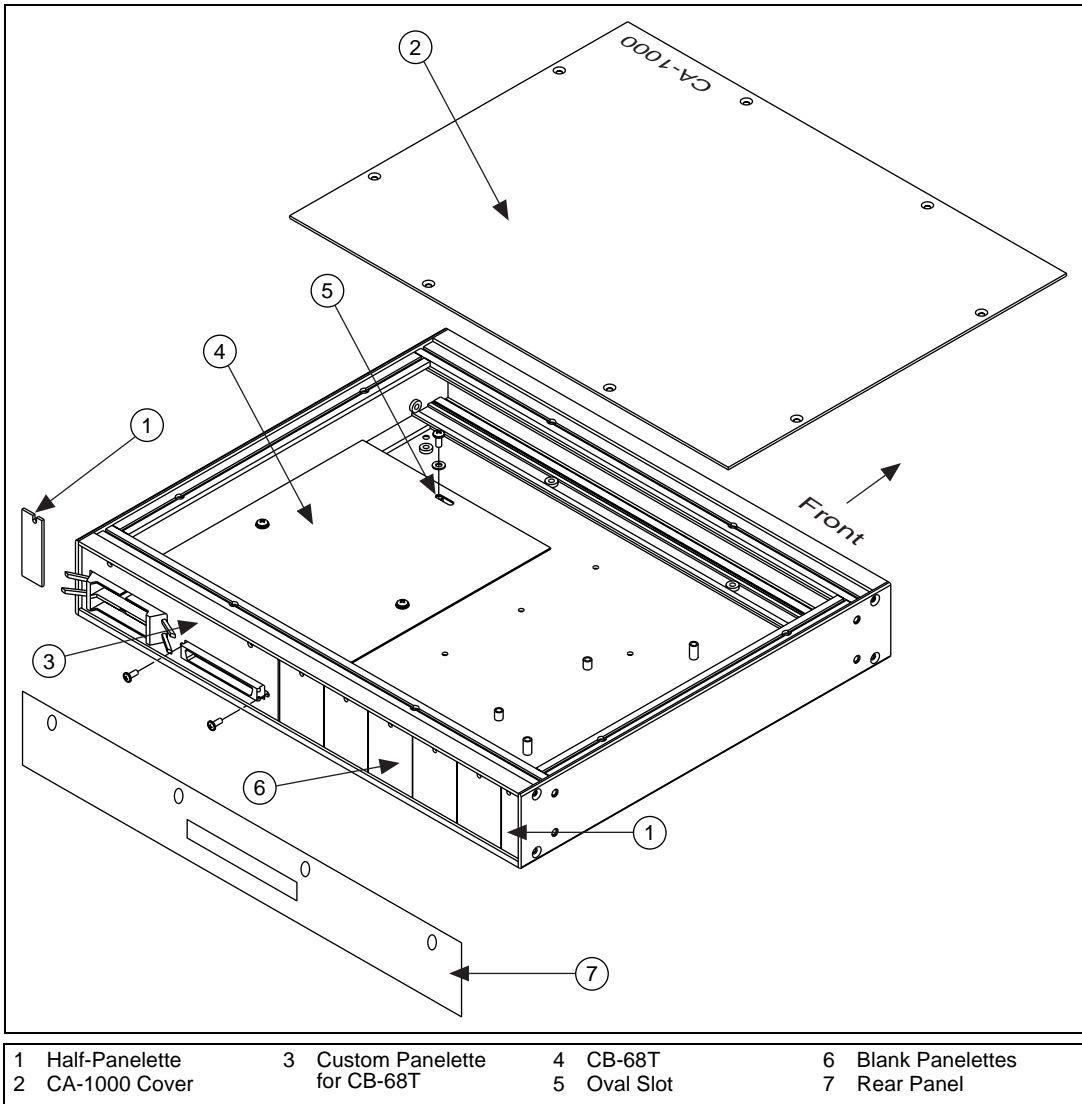
**Note** The CA-1000 can hold up to two CB-68T units or one CB-68T unit and one digital signal conditioning accessory, if desired.

4. Install the custom panelette provided with the CB-68T on the side that the half panelette was removed from in step 3.
5. Insert the CB-68T in the CA-1000 enclosure so that the 68-pin connector comes through the opening in the custom panelette. Attach the CB-68T with the screws provided.
6. Place the washer on the screw and screw it into the oval slot in the CB-68T board.
7. Install up to five blank panelettes (p/n 184483-01) in the rear of the CA-1000 enclosure to fill openings. Tighten the screws with a Phillips-head screwdriver.
8. Install the desired connector panelettes in the front of the CA-1000 enclosure (for example, thermocouple connector, BNC, banana jacks, strain relief, and so on). Refer to the *CA-1000 Configurable Connector Accessory Enclosure Installation Guide*.

9. Connect your signal wires as directed in the *Signal Connection* section of this document.
10. Replace the CA-1000 top cover.



**Note** To enable direct cabling on the CB-68T to an accessory in the same CA-1000 enclosure, you can optionally install two standard vertical 50-pin connectors on the CB-68T in the locations provided. Do not connect an accessory to the external accessory connector if you are using the internal accessory connector.



**Figure 1.** CB-68T Installation

# Signal Connection

---

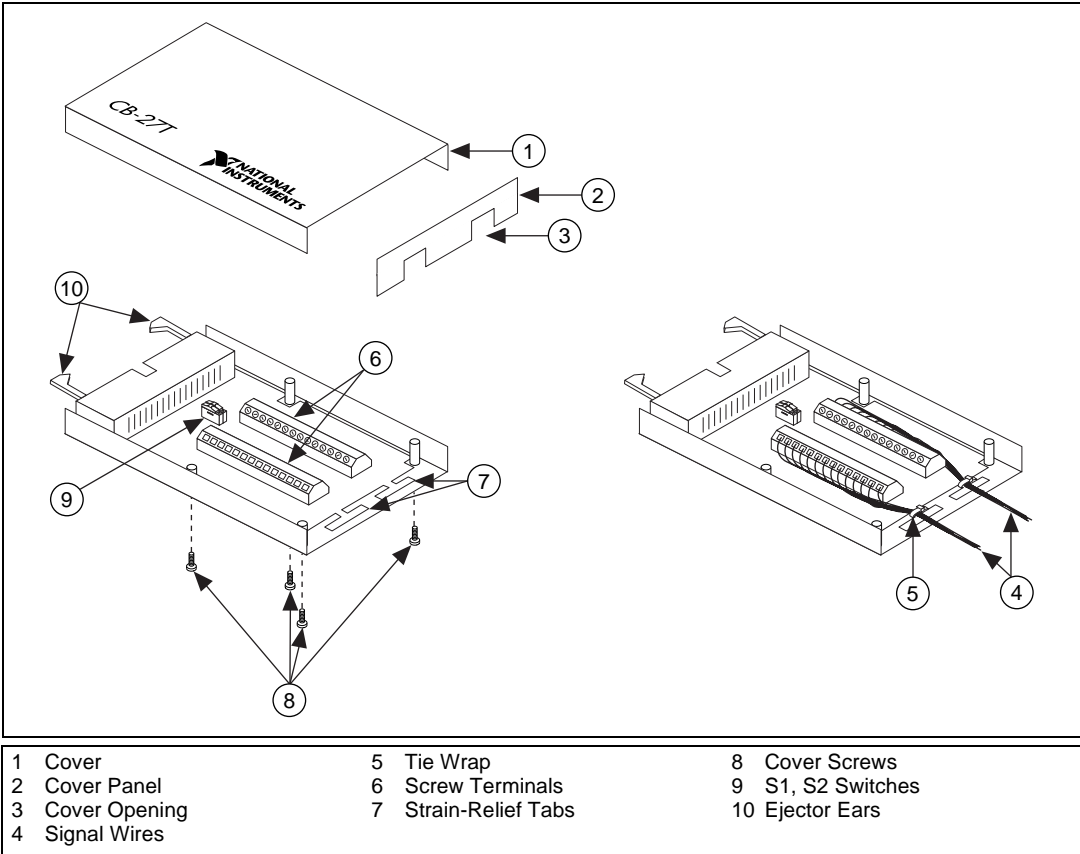
See your *NI 4350/4351 User Manual*, Appendix B, *Signal Connections*, for examples of how to connect your signals. Refer to Figures 2, 3, and 4 as you perform the following steps to connect your signals to your terminal block:

1. Remove the CB-27T or TBX-68T terminal block cover by unscrewing the four cover screws in the cover corners using the Phillips-head screwdriver.
2. Remove the front panel of the CB-27T.
3. Use wire cutters and wire insulation strippers to strip the wire ends as necessary to connect them to screw terminals.
4. Loosen the screws in the screw terminals with a 1/8 in. flathead screwdriver.
5. Insert the stripped wires into the screw terminals. Tighten the screw terminals with the 1/8 in. flathead screwdriver.
  - If you use digital signal conditioning accessories on the TBX-68T or CB-68T, lock the cable connectors in place with the ejector ears.
6. Make sure your signal wires can exit through the CB-27T or TBX-68T terminal block cover panel opening. On the CB-27T, you can use tie-wraps to tie the wires to the strain-relief tabs. On the CB-68T, you can use a strain-relief panelette or wire the signals to a variety of available connector panelettes (thermocouple, BNC, banana, and so on) made for the CA-1000 enclosure.

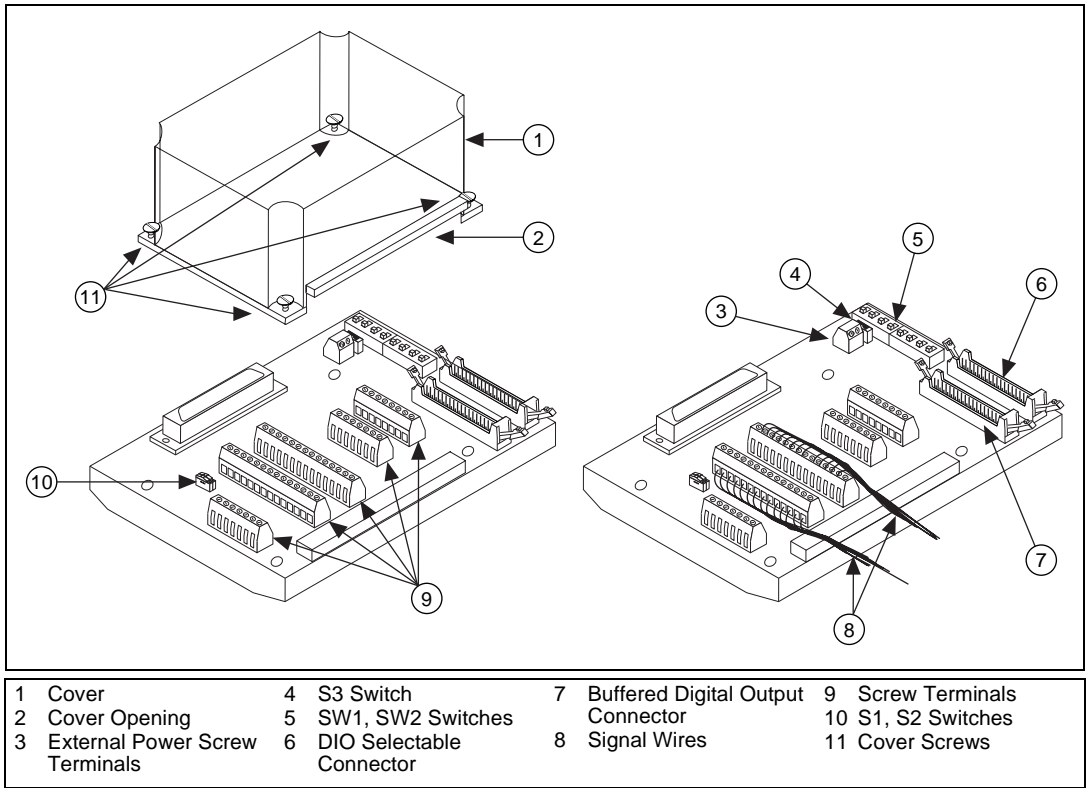


**Note** The TBX-68T and CB-68T terminal blocks do not provide strain relief for signal wires. Add strain relief and insulation for your signal wires, if necessary.

7. Replace the front panel of the CB-27T.
8. Replace the terminal block cover and tighten the cover screws.



**Figure 2.** CB-27T Parts Locator Diagram



**Figure 3.** TBX-68T Parts Locator Diagram

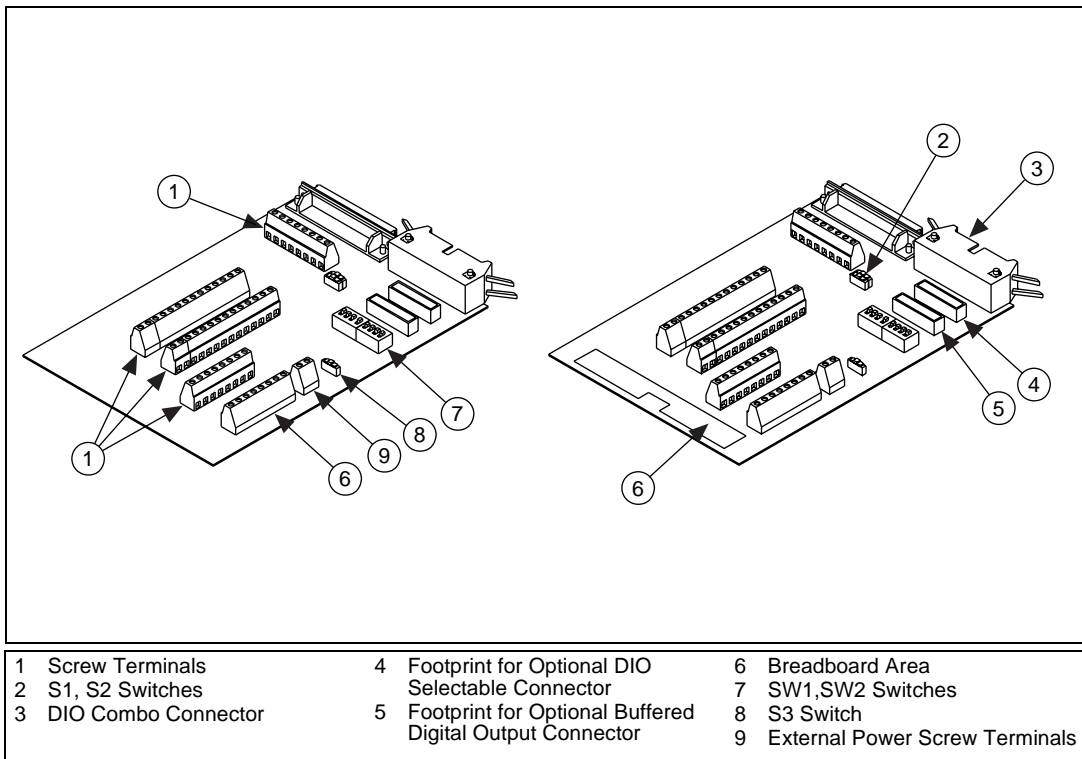


Figure 4. CB-68T Parts Locator Diagram

## Installing Your Terminal Block



**Note** To minimize the temperature gradient inside the terminal block and thus maintain its isothermal nature for accurate cold-junction compensation, place the terminal block away from extreme temperature differentials.

Refer to Figures 5, 6, and 7 as you perform the following steps to connect the terminal block to the NI 435X connector:

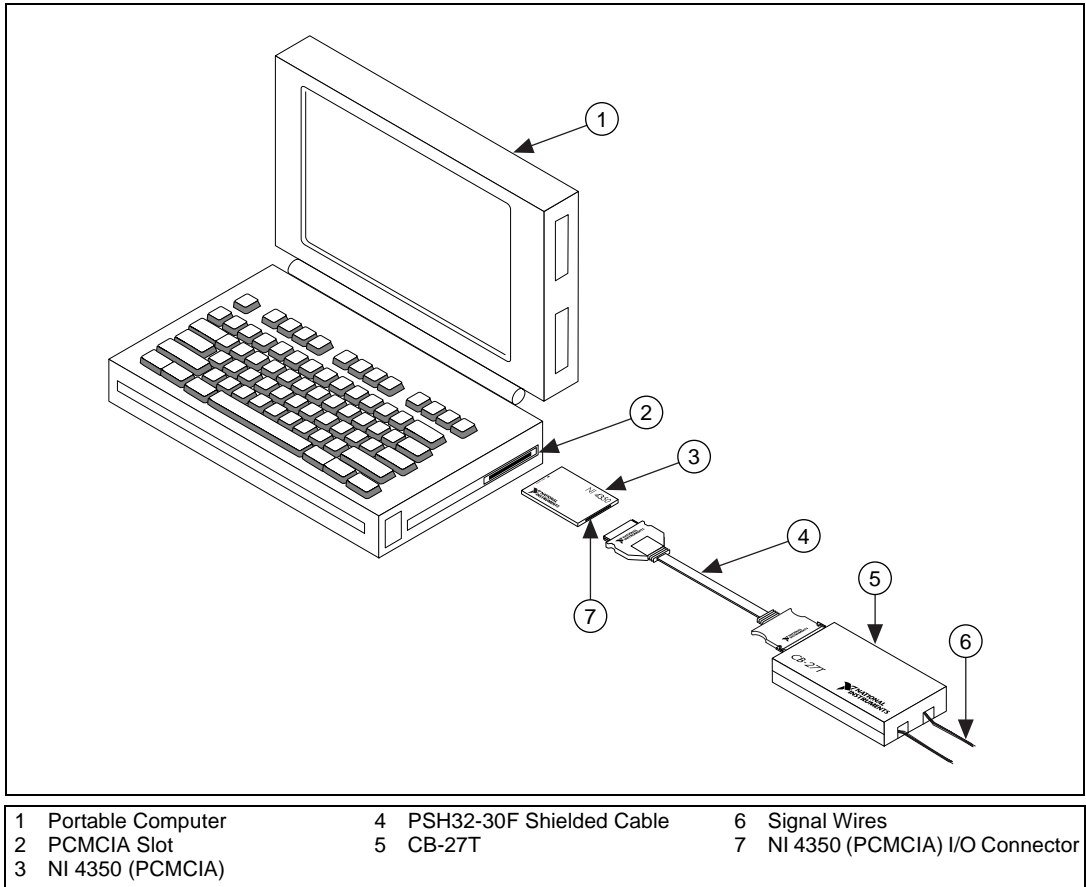
1. Attach one end of the cable to the NI 435X.
2. Attach the other end of the cable to the terminal block.
  - On the CB-27T, use the ejector ears to lock the cable connector in place.
  - On the TBX-68T and CB-68T, if you use the SH6868 cable, the two connectors should snap together. The R6868 ribbon cable has no latches and should simply join together without a snap.



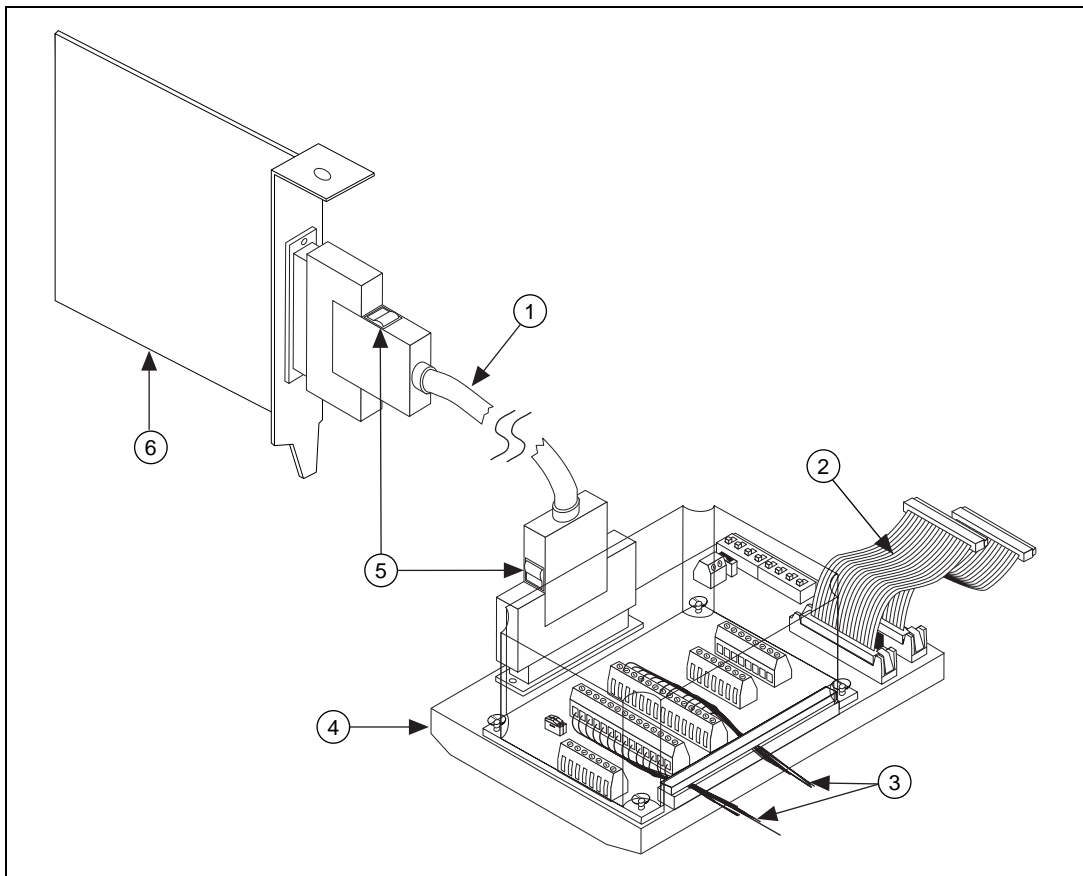
To disconnect the cable from the CB-27T and accessories from the TBX-68T or CB-68T, press outward on the ejector ears; the cable should pop out. To disconnect the SH6868 cable from the TBX-68T or CB-68T, push the two ejector ears on the backshell of the cable and gently pull on the backshell. Do *not* pull the cable.



**Caution** The connectors of both the NI 435X and the cable are polarized. You can attach them in only one way. Do not force the cable when inserting it into or removing it from the NI 435X connector.

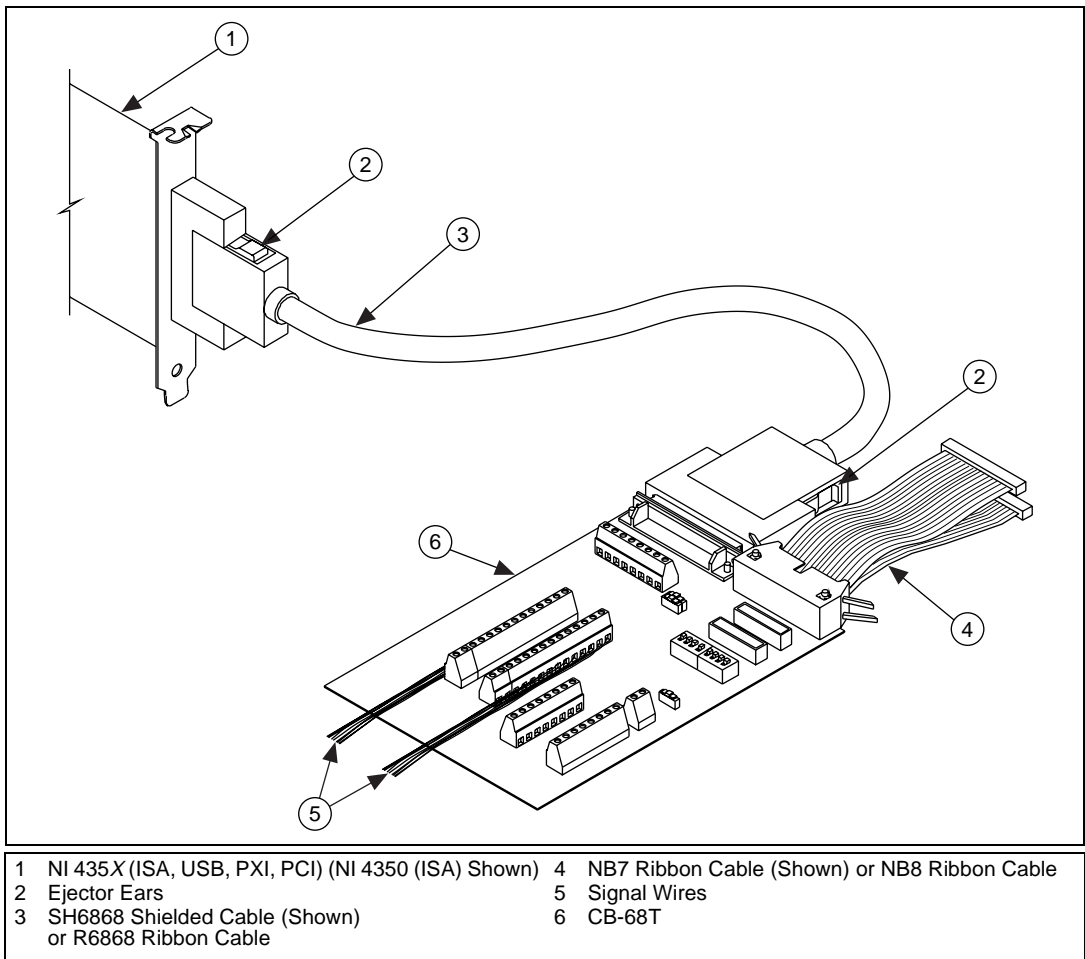


**Figure 5.** Connecting the CB-27T Cable Assembly



- |  |  |
|--|--|
| 1 SH6868 Shielded Cable (Shown)<br>or R6868 Ribbon Cable | 4 TBX-68T  |
| 2 NB7 Ribbon Cable (Shown) or NB8 Ribbon Cable           | 5 Ejector Ears                                       |
| 3 Signal Wires   | 6 NI 435X (ISA, USB, PXI, PCI) (NI 4350 (ISA) Shown) |

**Figure 6.** Connecting the TBX-68T Cable Assembly



**Figure 7.** Connecting the CB-68T Cable Assembly

# Rack-Mounting the TBX-68T or CB-68T

---

When you have completed signal connections and terminal block installation, you can mount the TBX-68T assembly into your rack. If you are using the National Instruments TBX rack-mount assembly, refer to the *TBX Rack-Mount Kit Installation Guide* for instructions.

If you are not using this rack-mount assembly, mount the TBX assembly directly onto your DIN rail by snapping the TBX-68T bottom onto the DIN rail with a firm push.

To remove the TBX-68T from the DIN rail, place a flathead screwdriver into the slot above the terminal block base and pry it away from the rail.

If you are using the CB-68T, refer to the *CA-1000 Configurable Connector Accessory Enclosure Installation Guide* for instructions.



**Note** You cannot mount the CB-27T onto a rack.

## Using the Current Source

---

You can use the current sources on the NI 435X to provide excitation for RTDs, thermistors, and other resistors. Follow the instructions in the *NI 4350/4351 User Manual* to connect your signals.

The screw terminals on the terminal block labeled IEX+, IEX0+, IEX1+, IEX-, IEX0-, and IEX1- provide external access to this current source. IEX+, IEX0+, and IEX1+ are the current outputs and IEX-, IEX0-, and IEX1- are the current returns. To enable external access of the current source IEX or IEX0, push both slide switches S1 and S2, shown in Figures 2 and 3, to the On position.



**Note** To measure the cold-junction temperature sensor while you are not using the current source externally through IEX+ and IEX-, push the slide switches S1 and S2 to the Off position.



**Note** IEX+ and IEX- are equivalent to IEX0+ and IEX0- on the TBX-68T and CB-68T.

# Cold-Junction Temperature Sensor

---

The CB-27T, TBX-68T, and the CB-68T cold-junction temperature sensors consist of a precision thermistor excited by the 25  $\mu\text{A}$  current source on the NI 435X. At 25  $^{\circ}\text{C}$ , the resistance of the thermistor is 5,000  $\Omega$ . The thermistor resistance varies from 16,305  $\Omega$  to 1,492  $\Omega$  over a 0–55  $^{\circ}\text{C}$  temperature range. The corresponding sensor output voltage varies from 408–37 mV over this temperature range.

To select and read the temperature sensor, refer to your software documentation for programming information.

Alternatively, you can use the following formulas to convert the cold-junction sensor voltage to cold-junction temperature:

$$T(^{\circ}\text{C}) = T_K - 273.15$$

where  $T_K$  is the temperature in kelvin.

$$T_K = \frac{1}{a + b \cdot \ln R_T + c \cdot (\ln R_T)^3}$$

where:

$$a = 1.295361 \times 10^{-3}$$

$$b = 2.343159 \times 10^{-4}$$

$$c = 1.018703 \times 10^{-7}$$

$R_T$  = resistance of the thermistor in ohms

$$T(^{\circ}\text{F}) = \frac{T(^{\circ}\text{C}) \cdot 9}{5} + 32$$

where  $T(^{\circ}\text{F})$  and  $T(^{\circ}\text{C})$  are the temperature readings in degrees Fahrenheit and degrees Celsius, respectively.

# Using Digital Signal Conditioning Accessories

You can connect the TBX-68T and the CB-68T to up to two of the following accessories at one time:

- SSR 8-channel backplane for use with SSR (Solid-State Relay) Series digital signal conditioning modules
- SC-206X Series digital signal conditioning boards
- ER-8 electromechanical relay accessory

Use one of the following cable assemblies to connect these accessories to the TBX-68T or CB-68T. Refer to Table 1 for connection information.

- Use the NB8 ribbon cable for the SSR 8-channel backplane. Refer to the *SSR Series User Manual* for more information.
- Use the NB7 ribbon cable for the SC-206X Series digital conditioning boards and the ER-8 electromechanical relay accessory. Refer to the *SC-206X Series User Manual* and the *ER-8/16 User Manual* for more information.

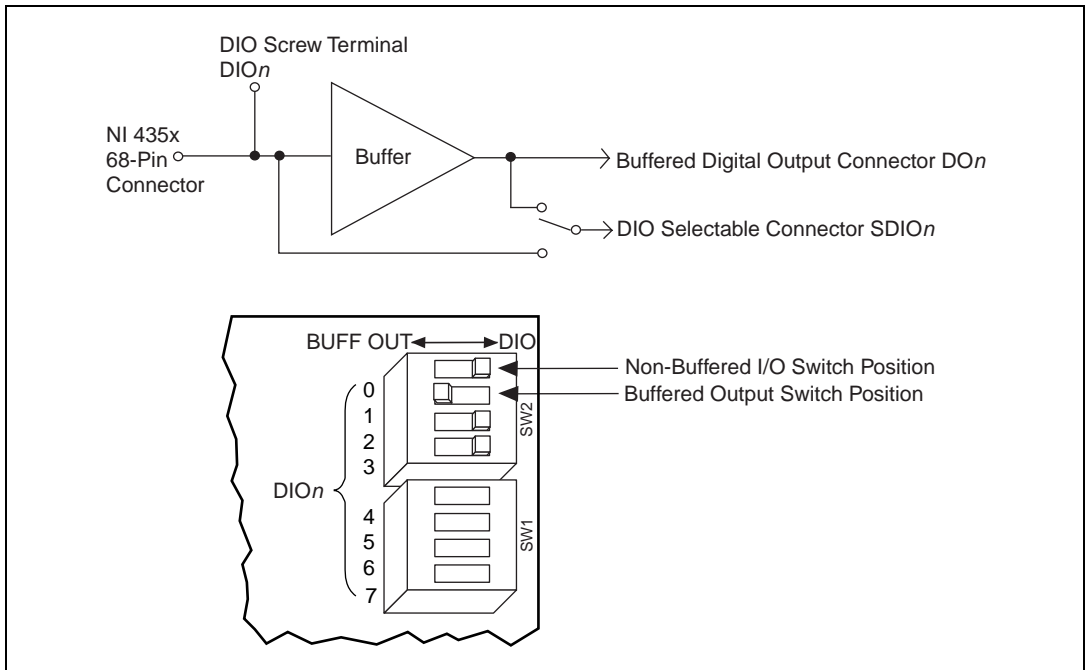
**Table 1.** Configuration Guide for the TBX-68T and CB-68T

Digital Signal Conditioning Connector	Function	Accessory	Cable
Nonbuffered Individual Line Switch-Selectable Input/Output	Input	SC-2060—8 optically isolated digital inputs	NB7
		SSR-8—8 solid-state input relays	NB8
	Output	ER-8—8 low-cost electromechanical relays	NB7
		SC-2061—8 optically isolated digital outputs	NB7
SC-2062—8 electromechanical relays		NB7	
Buffered Output	Output	ER-8—8 low-cost electromechanical relays	NB7
		SC-2061—8 optically isolated digital outputs	NB7
		SC-2062—8 electromechanical relays	NB7
		SSR-8—8 solid-state output relays	NB8

Refer to Figures 3 and 4 to locate the following:

- A 26-pin individual channel, switch-selectable (SW1 and SW2) buffered output/nonbuffered I/O connector
- 26-pin buffered output connector
- Switch-selectable (S3) NI 435X/external 5 V power source for accessories screw terminal (J15)

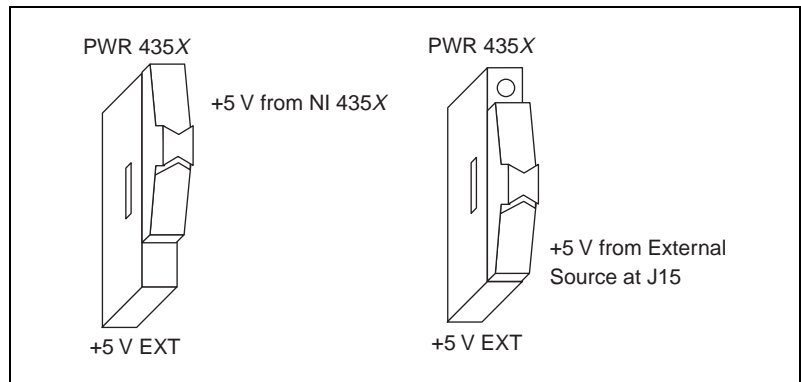
Refer to Figures 8 and 9 for switch settings.



**Figure 8.** DIO-Selectable Connector Switches (SW1 and SW2) on the TBX-68T and CB-68T



**Note** Digital input accessories attached to the DIO SELECTABLE connector will control the state of the corresponding digital lines of the BUFFERED DIGITAL OUTPUT connector.



**Figure 9.** Switch-Selectable 5 V Power Source for Accessories

Figures 10 and 11 show the pin assignments for the DIO-selectable and buffered digital output 26-pin connectors.

PWR 435X/+5 V EXT	1	2	DGND
PWR 435X/+5 V EXT	3	4	DGND
PWR 435X/+5 V EXT	5	6	DGND
PWR 435X/+5 V EXT	7	8	DGND
Buffered DIO 7	9	10	DGND
Buffered DIO 6	11	12	DGND
Buffered DIO 5	13	14	DGND
Buffered DIO 4	15	16	DGND
Buffered DIO 3	17	18	DGND
Buffered DIO 2	19	20	DGND
Buffered DIO 1	21	22	DGND
Buffered DIO 0	23	24	DGND
PWR 435X/+5 V EXT	25	26	DGND

**Figure 10.** 26-Pin Buffered Digital Output Connector Pin Assignments

PWR 435X/+5 V EXT	1	2	DGND
PWR 435X/+5 V EXT	3	4	DGND
PWR 435X/+5 V EXT	5	6	DGND
PWR 435X/+5 V EXT	7	8	DGND
DIO 7/Buffered DIO 7	9	10	DGND
DIO 6/Buffered DIO 6	11	12	DGND
DIO 5/Buffered DIO 5	13	14	DGND
DIO 4/Buffered DIO 4	15	16	DGND
DIO 3/Buffered DIO 3	17	18	DGND
DIO 2/Buffered DIO 2	19	20	DGND
DIO 1/Buffered DIO 1	21	22	DGND
DIO 0/Buffered DIO 0	23	24	DGND
PWR 435X/+5 V EXT	25	26	DGND

**Figure 11.** 26-Pin DIO-Selectable Connector Pin Assignments



# Specifications

---

Cold-junction temperature sensor accuracy <sup>1</sup> .....	0.06 °C from 15 to 35 °C 0.2 °C from 0 to 15 °C and 35 to 55 °C
Isothermal accuracy .....	0.1 °C
Compatible DIN rails .....	DIN EN 50 022 DIN EN 50 035
Terminal block dimensions	
CB-27T .....	11.7 × 7.0 × 2.3 cm (4.6 × 2.75 × 0.9 in.)
TBX-68T .....	16.28 × 12.57 × 8.43 cm (6.41 × 4.95 × 3.32 in.)
CB-68T .....	16.7 × 16.5 × 3.2 cm (6.6 × 6.5 × 1.25 in.)
Max working voltage <sup>2</sup> (signal + common mode) .....	Each input should remain within ±42 V of ground

## Digital Output Specifications (max):

Non-buffered digital I/O <sup>3</sup> .....	8 mA source/8 mA sink
Buffered digital output .....	15 mA source/64 mA sink

---

<sup>1</sup> Includes only the thermistor accuracy. The combined effects of the temperature sensor accuracy, as well as the current source tolerances due to tolerances in all component values in the NI 435X, the effects caused by temperature and loading, and self-heating and current leakage are discussed in the *NI 4350/4351 User Manual*.

<sup>2</sup> Refer to the NI 435X maximum working voltage specification; use the lower number of the two.

<sup>3</sup> Refer to the *NI 4350/4351 User Manual*.



321613C-01

Dec99